

Speed Control of DC Motor Using PICAXE Microcontroller

Othman Bensaoud ^{1, (*)} & Arash Tokhmechi ²

1 Dept. of Electrical and Electronic Engineering, Zawia University, Libya

2 Dept. of Electrical and Electronic Engineering, Murdoch University, Australia

Abstract

It is important to control the speed of DC motor in many applications, where precision and protection are essential. This paper is mainly concerned on DC motor direction and speed control system using microcontroller PICAXE. Pulse Width Modulation (PWM) technique is used where its signal is generated in microcontroller. The PWM signal is sent to motor driver to vary the motor voltage supply at constant speed. Direction of rotation of DC motor is changed by initiating an interrupt

(*) Email: O.bensaoud@zu.edu.ly

signal to the microcontroller using toggle switches. To drive the DC motor, a Darlington transistor array circuit was used. Through this paper, it can be concluded that microcontroller PIC AXE can perform many functions such as ramping speeds, speed control, indicators for various modes of operation, forward vs reverse.

Keywords — *Microcontroller(PICAXE), Darlington array, Dc Motor, PWM(Pulse Width Modulation), MOSFET,*

1. Introduction

Direct current motor (DC) is a device that used in many industries in order to convert electrical energy into mechanical energy. This is all result from the availability of speed controllers is wide range, easily and many ways. In most applications, speed control is very important. For example, if we have DC motor in radio controlled car, if we just apply a constant power to the motor, it is impossible to maintain the desired speed. It will go slower over rocky road, slower uphill, faster downhill and so on. Therefore, it is important to make a controller to control the speed of DC motor in desired speed [1]. DC motor plays a significant role in modern industry. The purpose of a motor speed controller is to take a signal representing the demanded speed, and to drive a motor at that speed. There are numerous applications where control of speed is required, as in rolling mills, cranes, hoists, elevators, machine tools, transit system and locomotive drives. These applications may demand high-speed control accuracy and good dynamic responses.

With the development of technology, microcontroller is becoming more suitable solutions to control various electro-mechanical devices [2-3]. Microcontrollers are used in automatically controlled products and devices. By reducing the size and cost, microcontrollers make it

with respect to control even more devices and processes. To obtain variable speed of DC motor, usually armature current and field currents are varied. But the range of speed variation is good if armature current can be varied. To get variable DC voltage chopper or PWM circuit can be used. PWM is routinely used to control the speed of DC motors. But designing and implementing the chopper or PWM circuit is very cumbersome [8]. This paper reports a microcontroller based control system to change the speed and direction of rotation of DC motor. Armature current is varied by pulse width modulation (PWM) of DC input voltage by using the microcontroller that sends the signals at the microcontroller's PWM terminal. Thus, the speed of the DC motor is changed. Direction of rotation of DC motor is changed by switching the signals polarity at armature terminals of the DC motor by initiating an interrupt signal to the microcontroller. Hardware implementation was done using an a "project board", which contained a PICAXE and a Darlington array. The PICAXE18M2 is the chosen microcontroller used within the project. Used in conjunction with a darlington array the control board gives ability to control input and output signals to and from the circuit board.

2. System Overview

The system mainly consists of PICAXE18M2 microcontroller board, DC motor, and power supply circuit. The speed and direction of motor changed by MOSFET and two relays. Two toggle switches are used for variation of pulses that is for speed change and another switch is used to control the direction. LED is used for visual indication. The system hardware block diagram is shown in figure 1.

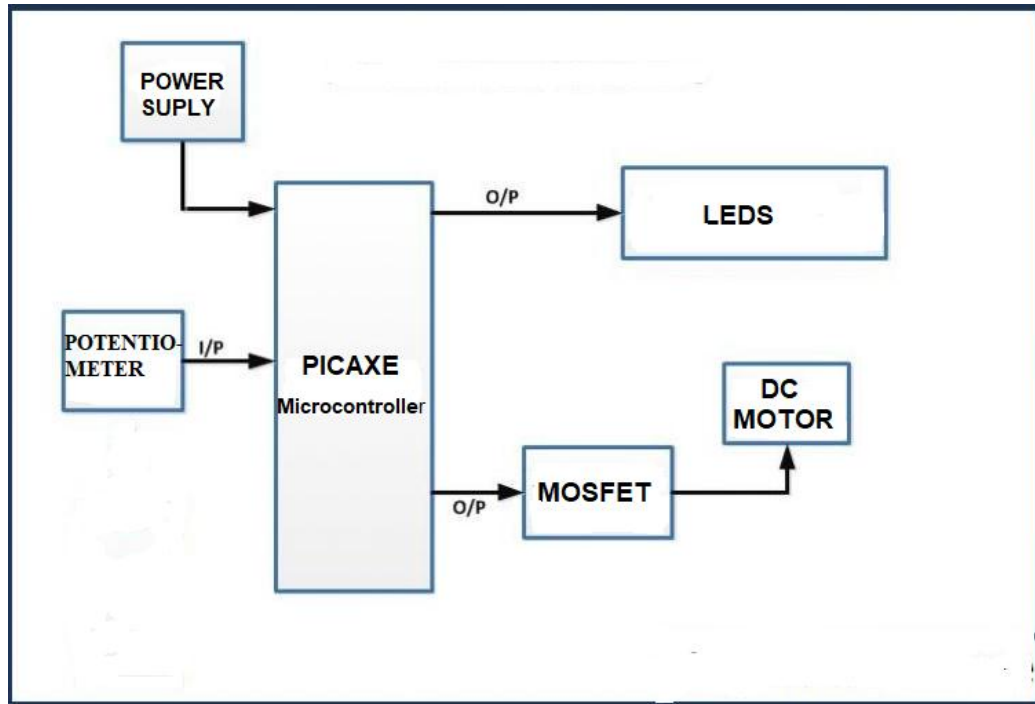

Figure1 .Block Diagram of Speed Control of DC Motor

2.1 PWM

Pulse width modulation (PWM) is a method for binary signals generation, which has 2 signal periods (high and low). The width (W) of each pulse varies between 0 and the period (T).

The duty Cycle(D) can be calculated by:

$$D = \frac{\tau}{T}$$

Where

τ is the duration that the time signal is in high state.

T is the period of the cycle

Pulse-width modulation (PWM), as it applies to motor control, is a way of delivering energy through a succession of pulses rather than a

continuously varying (analog) signal. By increasing or decreasing pulse width, the controller regulates energy flow to the motor shaft.

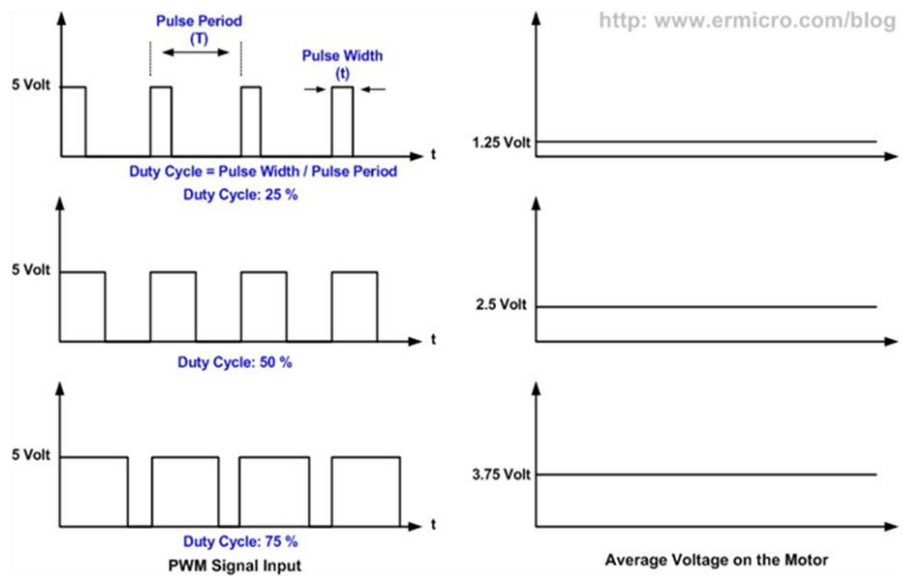

Figure 2. Pulse Width Modulation Waveforms

Figure 2 shows PWM waveform at 25,50,and 75 % The average DC Voltage value for 0% duty cycle is zero; with 25% duty cycle the average value is 1.25V (25% of 5V). With 50% duty cycle the average value is 2.5V, and if the duty cycle is 75%, the average voltage is 3.75V and so on. The maximum duty cycle can be 100%, which is equivalent to a DC waveform [4]. Thus, by varying the pulse-width, we can vary the average voltage across a DC motor and hence its speed.

2.2 PICAXE-18M2

Figure .3 shows the PICAXE-18M2 microcontroller chip which supports up to 16 inputs/outputs with 10 analogue/touch sensor channels [10]. It is very popular in education due to its low cost and small size, but also very popular in a wide range of hobbyist projects.

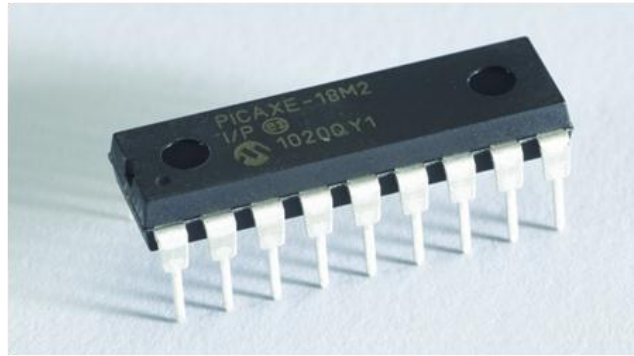

Figure3. PICAXE-18M2

Features:

- 28 bytes of variable space
- Multitasking.
- Total Ram 256(bytes).
- low-cost, simple to construct circuit
- 6 inputs, 810outputs
- 3 -5 VDC Operation
- Rapid download via serial cable
- Free, easy to use Programming Editor software
- Simple to learn BASIC language

2.3 pin project board

The 18 pin project board contains a 18M2 PICAXE microcontroller and a Darlington array as shown in figure .4. A Darlington array contains transistors and gives protection for the PICAXE, also allows more power and current to be used on the outputs. This board is modified with some additionally hardware (screw terminals, LEDs, button) to facilitate and speed the process of learning and using the system.

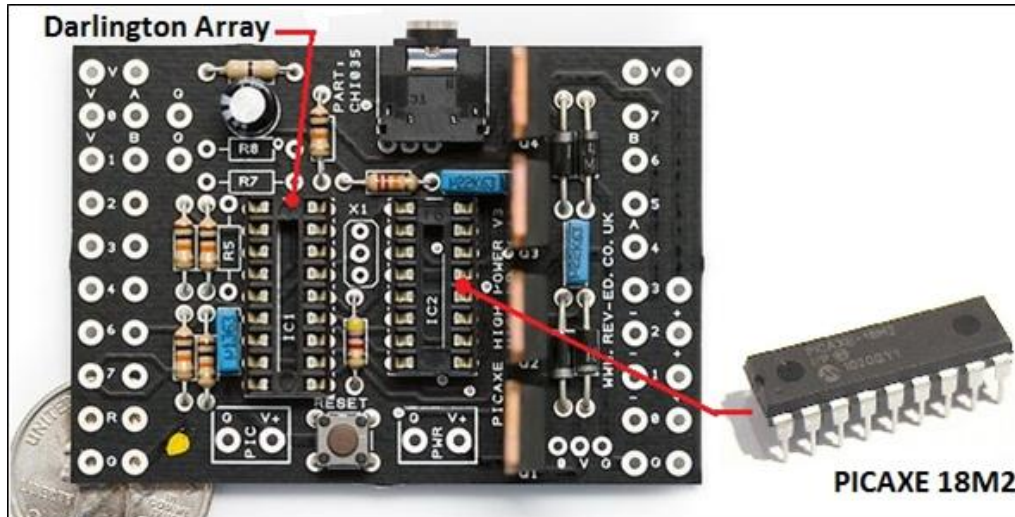

Figure 4. PicAXE Development Board [18 pin project board]

Features :

- 500-mA Rated Collector Current (Single Output)
- High-Voltage Outputs . . . 50 V
- Output Clamp Diodes
- Inputs Compatible with Various Types of Logic
- Relay Driver Applications
- Compatible with ULN2800A Series

2.4 DC motor

Dc motor is an electronic device that runs on direct current electrically. Direct current (DC) motor has already become an important drive configuration for many applications. Figure.5 shows the DC motor used in this project.

Advantages:

- Low initial cost
- High reliability
- Simple control speed



Figure 5.DC motor

2.5 The Voltage Regulator Circuit

The voltage regulator circuit is used in the circuit to obtain a 5V voltage while sharing a common ground. This allows the use of low voltage signals (5V) and higher voltage (12V) output controls for relay coils etc. The voltage regulator used in the circuit is a 5V output regulator and is connected with a 100uF capacitor across the 12V side for filtering.

2.6 MOSFET

The MOSFET ICs are used to provide the high-current, high speed switching required by the PWM to power the motor. Figure 6 shows the MOSFET that used in this project. The MOSFET in the circuit allows it to be switched. This switching is controlled by the PWM output signal on the control board. As a positive voltage is applied to the MOSFET gate the resistance between the drain and source decreases.

This ability to switch the MOSFET quickly allows the use of a PWM to control the average voltage output to the motor, whereby controlling the field and therefore controlling the speed.

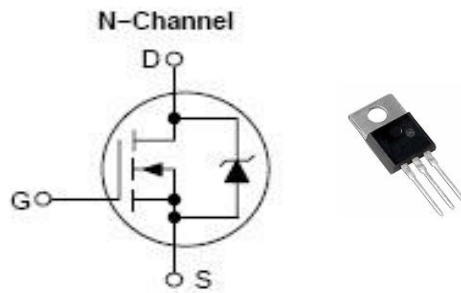

Figure 6. N-channel MOSFET

2.7 Potentiometer

A potentiometer is used with a resistive voltage divider in order to use a 10V input to control the motor speed.

2.8 Relay

A relay is used to make the DC motor rotate in two directions, forwards and reverse. In this project, it has been used two relays instead of a H- bridge to reverse the direction of the motor as shown below in figure.7.

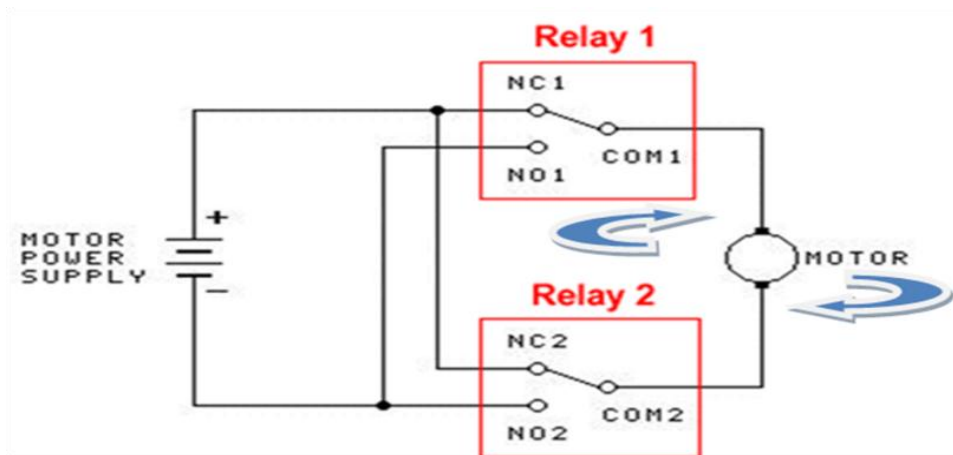

Figure7. Relay circuit diagram

DC motors rotation direction depends on the polarity of its power supply (ex. +/- forward, -/+ backward). So, if we can control polarity. The relay is like a switch, if both relays are on, then the current will flow from one direction, and if both are off the current will flow in the reverse direction.

2.2 Software Specification

The code was developed using PICaxe programming editor as shown in figure.8 to control a DC motor with the capability of providing forward direction, reverse direction and various other functions. The program starts off in a function named “main”. This loop contains all the required code to control the motor. Outside of this function are other sub functions which are called when required by the main loop.

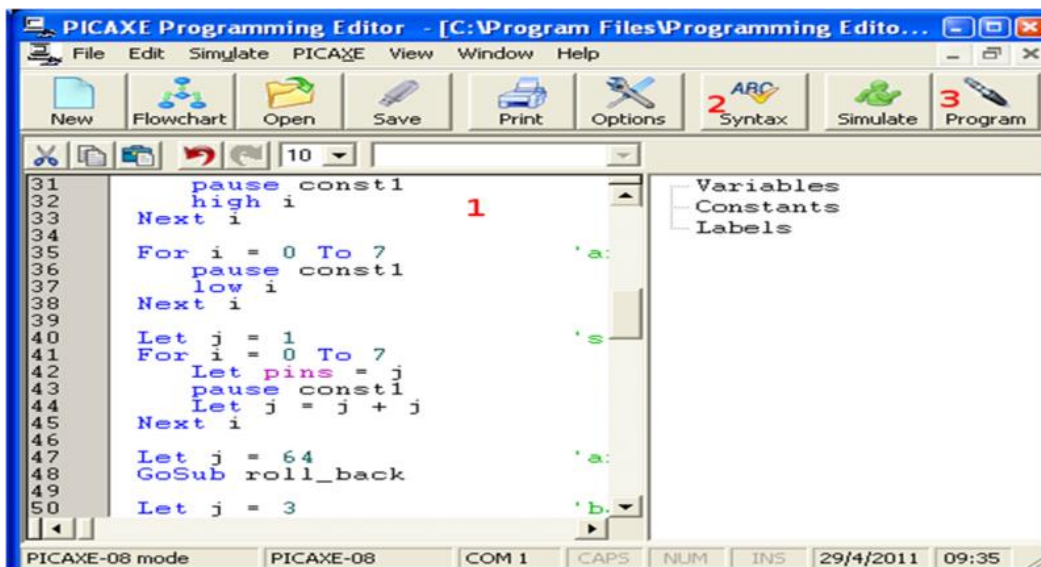

Figure 8 . PICaxe programming editor

3. Working Methodology

The whole system is implemented in the laboratory in bread boards and the photograph of the whole system with DC motor is shown in Fig9..For controlling the speed of DC motor, we use a 100K ohm potentiometer to change the duty cycle of the PWM signal. The potentiometer is connected to the analog input pin A0 of the microcontrollers and the DC motor is connected to the digital output pin of the microcontroller (which is the PWM pin).

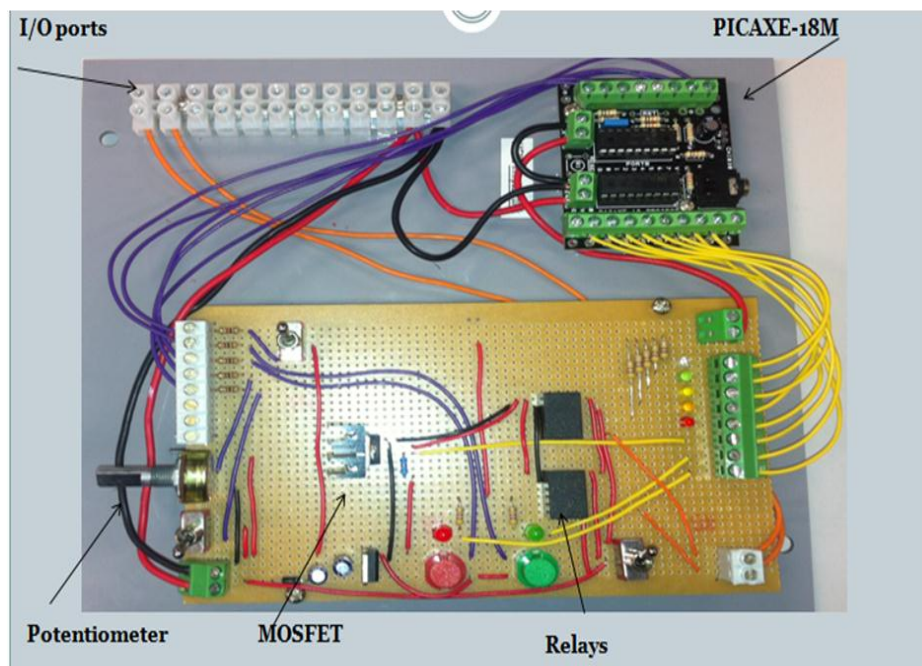

Figure 9. Photograph of the DC motor control system

As the start switch is turned on, it reads the voltage from the analog pin A0. The voltage at analog pin is varied by using the potentiometer. After doing some necessary calculation the duty cycle is adjusted. For example, if the analog input is fed with value of 256, then the HIGH time

will be 768ms (1024-256) and LOW time will be 256ms. Therefore, it simply means the duty cycle is 75%.

Note: The outputs from the micro-controller are turned on by the darlington array by switching to ground. Therefore, the 12V comes into the controller board and the board switches it to ground to complete the circuit.

3.1 Inputs and Outputs addresses

Listed Below are the correct input and output ports used and what is terminated to each.

Input Address (5V) :		
C.0	-	System ON/OFF (Toggle switch)
C.1	-	Analogue Input from Speed Control Potentiometer
C.2	-	Motor Forward Selection(Toggle 1 switch)
C.3	-	Motor Reverse Selection(Toggle switch)
Output Address (12V) :		
B.0	-	Unused
B.1	-	Forward Operation Selected Indicator
B.2	-	Reverse Operation Selected Indicator
B.3	-	12V PWM
B.4	-	Forward/Reverse Control Signal
B.5	-	Unused
B.6	-	Standby Indicator

3.2 Forward & Reverse Operation

The approach that we have used to control the direction is two relays instead of using 4 MOSFETS. The Forward/Reverse signals are operated by manual switching signals to inputs .The selector switch

allows the motor direction of rotation to change. This two way switch sends separate 5V signals to the microcontroller where each signal is used as inputs that get a different change to the program as the selection between forward and reverse is changed to program outputs a control signal to the relay coil that activates changing the configuration of the relays, therefore changing the configuration of the relays reversing the direction of current through the motor.

4. Results and Discussions

Figure. 10 shows the relationship between motor speed in rpm and PWM in percentage. As the PWM changes, the speed of the DC motor also changes. It has been observed that the speed of the motor increase gradually due to the increment of the duty cycle .

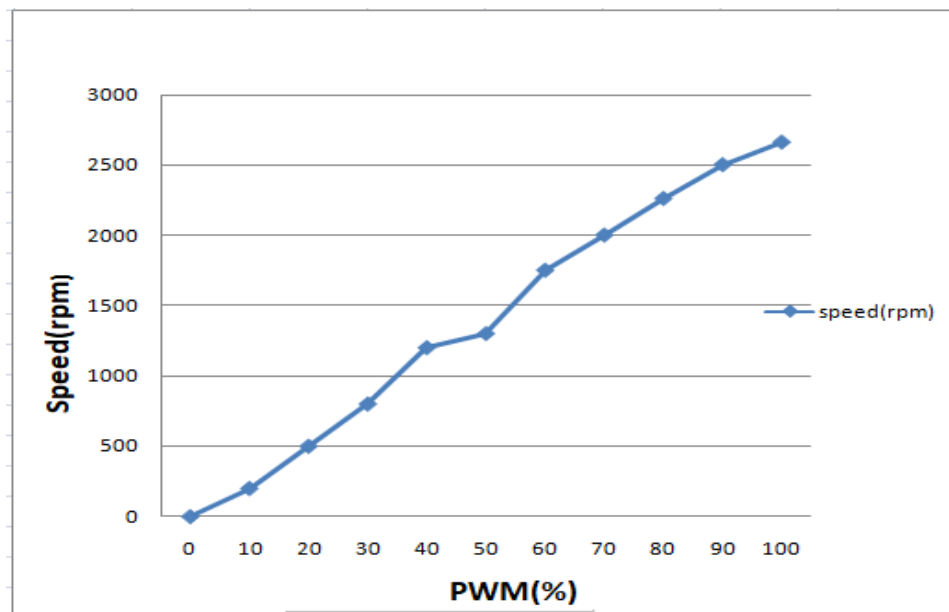

Figure 10. PWM in % vs. speed (rpm)

5. Conclusions

In this work, a microcontroller based DC motor control system design is described to change the speed and direction of rotation of DC motor. Armature current is varied by pulse width modulation (PWM) of input DC voltage. Direction of rotation of DC motor is changed by initiating an interrupt signal to the microcontroller. To drive the DC motor, a MOSFET and two relays integrated driver circuit with diode clamps was used. The motor speed was controlled using the potentiometer and PWM out function. The direction of the motor was reversed using the relay circuit—powered by voltage attached to the picaxe. The relay uses a double pole double throw system to allow this to occur. The LED's were used to indicate that the program was working and the state of the motor (i.e. whether it was in forward mode, reverse mode or speeding up/slowing down).

6. References

- [1]. *M. K. Russel, M. Haque .Bhuyan, “Microcontroller Based DC Motor Speed Control Using PWM Technique,” Proceeding of the International Conference on Electrical, Computer and Telecommunication Engineering 01- 02 December 2012 (ICECTE2012), RUET, Rajshahi-6204, Bangladesh, December 18-20, 1998, pp. 273 277.*
- [2]. *M. A. Rahade , S. S Jadhav, “Design and Implementation of DC Motor Speed Control Based on TMS Microcontroller”,Proceedings of International Conference on Computing and Information Technology,*

Aditya Engineering College, Beed, M.S. India., December 28-30, 2005, pp. 417-421.

[3]. P. A. Askar, A. R. Napha, R. V. Adle “Speed Control of DC Motor Using Microcontroller,”

Journal of Network Communications and Emerging Technologies (JNCET) Volume 7, Issue 3, March (2017), vol. 2, issue 1, pp. 44-49.

[4]. Katke S.P*1, Rangdal S.M2 “ Speed Control of DC Motor Using Microcontroller,” *IEEE*

Transactions on Industrial Electronics, India 2015 IJSRST ,Volume 1 , Issue 2 , Print ISSN: 2395-6011, Online ISSN: 2395-602X Themed Section: Science.

[5]. M. H. Bhuyan, M. A. Rabby, M. A. Parvez and M. M. G. Tarik, “Microcontroller Based

Display System Design using LED Array,” Proceedings of the Conference on Engineering

Research, Innovation and Education, Shahjalal University of Science and Technology, Sylhet,

Bangladesh, 11-13 Jan 2010, pp. 417-420.

[6]. D. DAVCEV, M. STOJKOSKA, and M. KALAJDZISKI, “Project Based Learning of Embedded Systems,” *2nd WSEAS Int. Conf. on CIRCUITS, SYSTEMS, SIGNAL and TELECOMMUNICATIONS (CISST'08) Acapulco, Mexico, January 25-27, 2008*

- [7]. V.Ramya1, B. Palaniappan, “Embedded Technology for vehicle cabin safety Monitoring and Alerting System,” *International Journal of Computer Science, Engineering and Applications (IJCSEA) Vol.2, No.2, April 2012.*
- [8]. Iovine John.” *PIC Microcontroller Project Book”. 2nd Edition. Singapore: McGraw-Hill. 121-123; 2000.*
- [9]. B. Sherston , B. Mossop, R. Liang , *ENG306 Embedded & Real-time System Design Project PICAXE Controlled Variable Speed DC Motor Drive, MurdochUniversty, Australia, 2011.*
- [10]. C. Seager, J. Bown, “*Picaxe Manual ,*” *Revolution Education Ltd, Uk, <http://www.Picaxe.com>, 2013.*